

CREATING A TEST/HOMEWORK ASSESSMENT:

1. Press MENU.
2. Highlight "Test/Homework" (use the YES button for down and the NO button for up).
3. Press ENTER.
4. Select "1" for New Test.
5. Use the number keys to enter a version number.
Press ENTER once you've entered the test version number.
6. The ResponseCard will prompt you to verify you've entered the correct information.
7. Select "YES."
8. You are now in the Test/Homework screen.
9. Enter the corresponding answer to the test/homework questions. You will receive confirmation that your answer is being stored.
10. Repeat step 10 until all of the questions are answered.
The maximum number of answers that can be stored is 100.
11. Press MENU when you have completed the assessment.
12. You will be prompted to leave Test Mode. Select "YES."
13. Select "2" to save the assessment and transmit at a later time.

** To submit the assessment immediately, press 1 to send to the host computer.*

EDITING A TEST/HOMEWORK ASSESSMENT:

1. Press MENU.
2. Highlight "Test/Homework" (use the YES button for down and the NO button for up).
3. Press ENTER.
4. Press 2 for "Manage Test."
5. Use the YES button to scroll down to select your test.
6. Press ENTER when the test you want to edit is highlighted.
7. Press 3 to "Edit Test."
8. Press YES to confirm that you have selected the correct test.
9. You can now use the YES and NO buttons to scroll through your test. You could also use the Go To button on the ResponseCard.
 - A. Press the Go To button.
 - B. Enter the 3-digit question number.
Ex. 004
10. To change the answer for the selected question, press a button on the ResponseCard that corresponds to the new answer choice.
11. Once all of the changes are made press MENU.
12. You will be prompted to leave Test Mode. Select "YES."
13. Select "2" to save the assessment and transmit at a later time

** To submit the test immediately, press 1 to send to the host computer.*

SUBMITTING A SAVED TEST/HOMEWORK ASSESSMENT:

1. Press MENU.
2. Highlight "Test/Homework" (use the YES button for down and the NO button for up).
3. Press ENTER.
4. Press 2 for "Manage Test."
5. Use the YES button to scroll down to select your test.
6. Press ENTER when the test you want to edit is highlighted.
7. Press 1 to Send Test.
8. You will receive confirmation that your test has been submitted.

THE SETUP MENU:

The Setup Menu has three options:

- Contrast
- Unit ID
- Version

Contrast - From this sub-menu you can adjust the contrast. Use the YES button to make the screen lighter, and the NO button to make the screen darker.

Unit ID - Displays the six digit device ID assigned to the ResponseCard.

Version - From this sub-menu you can see which version of the XR ResponseCard Firmware you currently have loaded.

FCC Statement

This product has been tested and found to comply with Part 15 of the FCC Rules. Operation is subject to the following conditions: it may not cause harmful interference and must accept interference received, including interference that may cause undesired operations.

Changes or modifications not expressly approved by the party responsible for compliance could void the user's authority to operate the equipment.

Canada Statement

This Class B digital apparatus complies with Canadian ICES-003.

Cet appareil numérique de la classe B est conforme à la norme NMB-003 du Canada.



***Turning
Technologies***

ORGANIZATION OWNED

Contact Us:

Customer Service Hours of Operation
Mon - Fri (7 a.m. - 9 p.m.)

Customer Service Line:
1-877-726-4602

Customer Service E-mail:
support@turningtechnologies.com



XR

ResponseCard® RF

User's Guide

PRODUCT SPECIFICATIONS:

Enclosure

- Lightweight, compact, card format
- Dimensions: 4.0" L x 2.5" W x 0.75" H
- Weight: 2.0 oz (with batteries)
- Angled LCD screen for optimum viewing
- Durable, rugged case ensures maximum longevity under extreme conditions

User Input

- 20 Key (1(A) - 10(J)), Answer Mode, Go To, Enter, Yes, No, Menu, Select, Clear, +/-, .(decimal)

Display

- Easy to read LCD Display
- Dimensions: 50 mm x 20 mm viewable area
- Display Features: Channel Number, Battery Life Indicator, Answer Choice, Response Confirmation

Power & Power Management

- Powered by two AAA batteries
- Average battery life is 6 to 12 months

This device is designed to be used with a standard USB cable no longer than 3 meters in length.

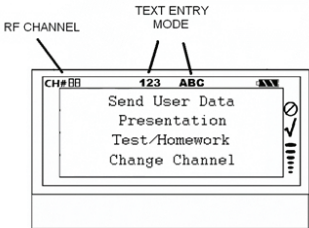
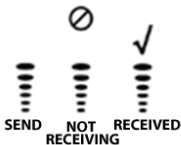

CHANGING CHANNEL:

1. Press MENU.
2. Highlight "Change Channel" (use the YES button for down and the NO button for up).
3. Press ENTER.
4. The next screen will display the current programmed channel. Use the numeric keys to enter the new channel.
5. Press ENTER when the the new channel number is entered.
6. You will then automatically be taken into Presentation Mode.

CREATE LOGIN ID:

1. Press MENU.
2. Highlight "LOGIN."
3. Press ENTER.

Your screen will display the following:

Enter Login ID:

VWXYZ 0123456789

<

16 Left

4. Enter the numeric login using the number pad on the ResponseCard.
5. Your choice will appear on the next line in front of the <. The number left will decrease by one each time.

6. Press ENTER when finished.
7. The Login ID is saved and sent to the host computer.
8. You will receive confirmation when your Login ID is sent successfully.

EDITING LOGIN ID:

1. Press MENU.
2. Highlight "LOGIN."
3. Press ENTER.

Your screen will display the following:

Current Login:

(login ID)

1 = Change Login

2 = Send Current

4. Select "1."
5. Enter your new Login ID by following steps 4-8 in "CREATE LOGIN ID."

SENDING LOGIN ID:

1. Press MENU.
2. Highlight "LOGIN."
3. Select "2" to send current login.
4. You will receive confirmation that you are now logged in, and will automatically be taken into Presentation Mode.

SENDING RESPONSES IN PRESENTATION MODE

**To be used during a live presentation when the speaker wants immediate feedback from the audience.*

1. Press MENU.
2. Highlight "Presentation" (use the YES button for down and the NO button for up).
3. Press ENTER.
4. Your screen will display the following:
Presentation
Mode
Channel Number
5. Press the button on the ResponseCard that corresponds to your answer choice.
6. Your answer can be verified on your screen after you make your selection.
Your Answer:
1/A
7. The checkmark will appear on the right-hand side of your screen confirming your answer was received.

**You may receive a message stating: Not accepting answers!*

This means that polling was closed and you may not have answered the question. If you sent a successful answer before polling closed, then TurningPoint will accept the last successfully transmitted answer.